

1981 CESSNA CITATION II | SN 550-0398



MACH
0.705



PASSENGERS
9



RANGE (NM)
1,600

CONTACT: DAVID LEE
david@soljets.com | +1.847.920.7000

1981 CESSNA CITATION II | SN 550-0398



AIRCRAFT LISTING DETAILS:

Total Hours: 8,866

ENGINES: Pratt & Whitney JT15D-4

	Left	Right
Total Hours:	8,468	11,747
Engine Cycles:	6,239	12,744
Hours Since Overhaul:	2,827	1,247
Cycles Since Overhaul:	2,397	1,130

AIRCRAFT HIGHLIGHTS:

- SierraTrax
- ADS-B In/Out
- New Carpet Completed October 2019
- Both Pilot Seats Rebuild and Recover Completed October 2019

AVIONICS:

- Sperry SPZ 500 Autopilot/Flight Director
- Aero Mech RVSM STC with Dual Thommen ADDU
- Dual Garmin GTN-750 for GPS/NAV/COMM
- Dual Garmin GAD 42 Adapter
- Garmin GMA 35 Remote Audio Processor
- Dual Garmin GTX-33ES ADS-B In/Out Remote Transponders
- Honeywell RDR 2000 Vertical Profile Color Weather Radar (Displays on #1 750)
- Bendix/King KGP 560 TAWS
- BFG SkyWatch HP TCAS
- Collins ALT-50A Radar Altimeter
- Sierra Industries Glareshield Mounted Annunciator Panel

1981 CESSNA CITATION II | SN 550-0398

FEATURES / OPTIONS:

- Branson GW Increase Kit
- Sierra Industries Quick Release Radome, Anti-Collision Lights, Remote Gear Horn Silence Switch
- Keith Vapor Cycle Air Conditioning
- Coffeyville Extended Baggage
- 3 Axis Articulating Cockpit Seats
- Rosen Tinted Sun Visors in Cockpit
- Aviation Fabricators two place side-facing couch
- Sheep Skin Pilot Seats
- New Carpet Completed October 2019
- Both Pilot Seats Rebuild and Recover Completed October 2019

INTERIOR:

Bravo Style Interior. Nine (9) Passenger Avion Wheat Leather Seating including a Six Executive Seats, Forward Side Facing Two Place Divan, and Belted Lav. Accented with Milkweed Ultra Leather Headliner, Red Radical Cabinetry, Birds In Flight Fabric Sidewalls, and New Carpet.

EXTERIOR:

Overall Matterhorn White Base Accented with Camel and Light Grey Striping.

1981 CESSNA CITATION II | SN 550-0398



MAXIMUM CRUISE SPEED

(30,500 ft / 9,300 m, mid cruise weight)	262 ktas	484 km/hr
--	----------	-----------

NBAA IFR RANGE (100 nm Alternate)

Full fuel, MTOW, and Max Cruise	1,600 nm	3,000 km
---------------------------------	----------	----------

AIRPORT PERFORMANCE (Dry, Level, Hard, Zero Wind)

Takeoff distance (SL, ISA, MTOW)	3,450 ft	1,050 m
Landing distance (SL, ISA, MTOW)	2,450 ft	745 m

CEILING

Maximum certified	43,000 ft	13,000 m
-------------------	-----------	----------

PRESSURIZATION

Nominal pressure differential	8.7 psi	.59 bar
-------------------------------	---------	---------

OUTSIDE DIMENSIONS

Overall length	47 ft 5 in	14.40 m
Overall height	15 ft 0 in	4.57 m
Wingspan	52 ft 2in	15.90 m

CABIN DIMENSIONS

Length (excluding cockpit)	190 in	4.83 m
Height	56 in	1.42 m
Width	58 in	1.47 m

WEIGHTS

Gross Weight	14,500 lbs	6,577 kg
Basic Empty Weight	8,203.64 lbs	3,721 kg
Useful Load	6,296.36 lbs	2,855 kg
Fuel Capacity	4,970 lbs	742 gal
Useful Load with Full Fuel	1,326.36 lbs	601 kg

1981 CESSNA CITATION II | SN 550-0398

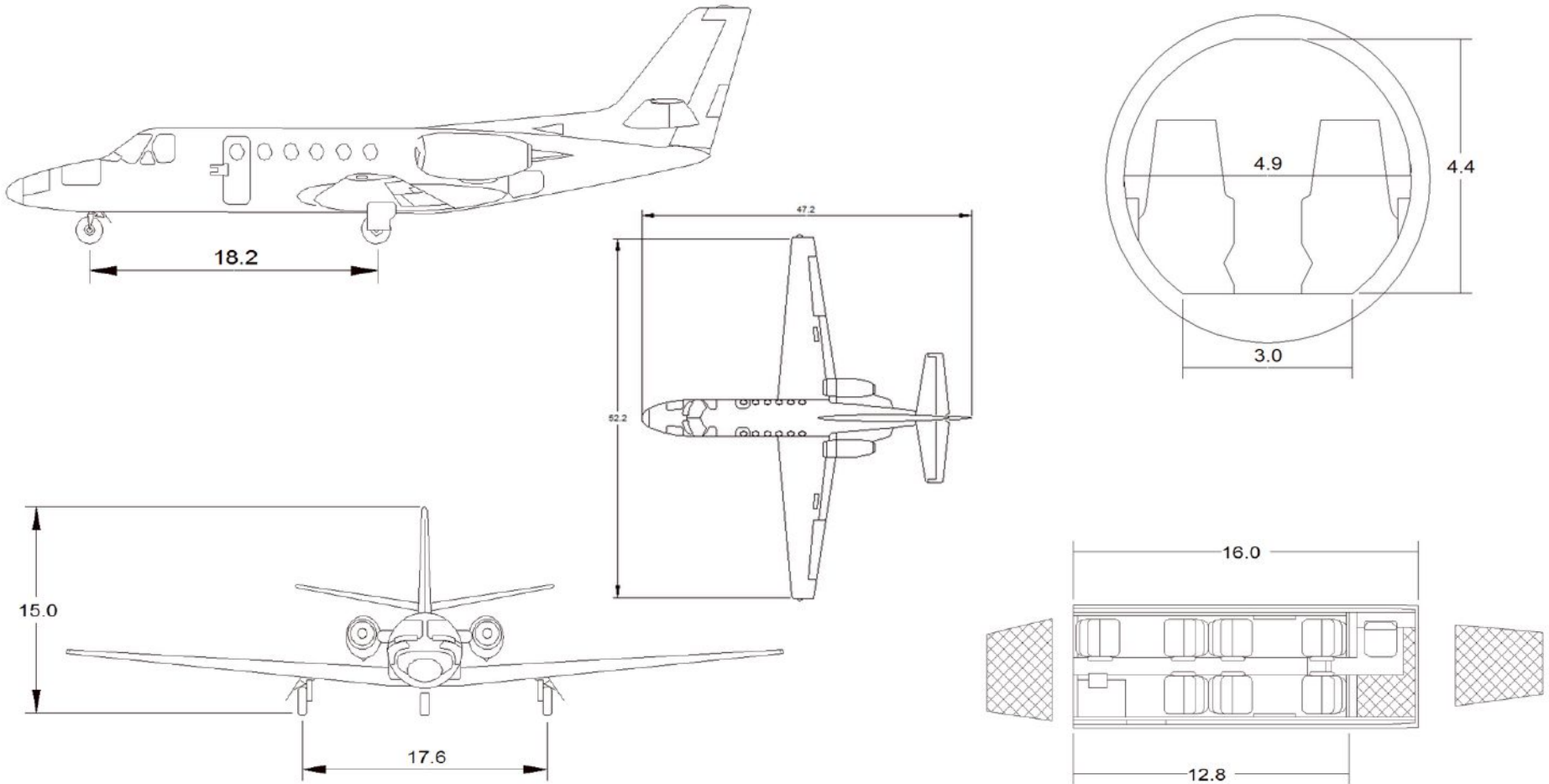

1981 CESSNA CITATION II | SN 550-0398



1981 CESSNA CITATION II | SN 550-0398





www.soljets.com

1981 CESSNA CITATION II | SN 550-0398



©Copyright – SOLJETS LLC- Aircraft Sales & Acquisitions ® 2019 - All Rights Reserved
Specifications Subject To Verification upon Inspection. Aircraft Subject To Prior Sale or Withdrawal from Market.

CONTACT: DAVID LEE
david@soljets.com | +1.847.920.7000

1981 CESSNA CITATION II | SN 550-0398



1981 CESSNA CITATION II | SN 550-0398



1981 CESSNA CITATION II | SN 550-0398



1981 CESSNA CITATION II | SN 550-0398

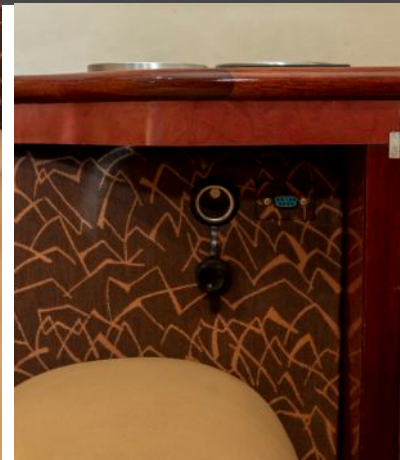

1981 CESSNA CITATION II | SN 550-0398



SOLJETS: YOUR TRUSTED PARTNER

EXPERIENCE, KNOWLEDGE, PASSION

Whether you have a precise requirement for a specific aircraft, or a vague concept and understanding of your needs, the SOLJETS professionals have refined a SOLUTION that ensures YOUR needs, missions, and goals are met. With clarity we work together to provide the Intel and resources to enable YOU to make the best decisions – whether buying or selling. The SOLJETS SOLUTION has four key steps: Assess, Assemble, Act, Alliance.

SOLJETS' FOCUS IS YOU

The SOLJETS SOLUTION™ combines the ideal aircraft with the right process, ownership structure, and foundation to make sure that your jet is a simple, efficient, and satisfying part of your life. Freedom, adventure, time. With SOLJETS, that dream can become a reality.

LEVERAGING ART & SCIENCE

Matching the right aircraft with the right owner takes more than internet advertising and email campaigns. The team at SOLJETS leverages industry relationships built over decades of experience to broaden our global reach and uncover unique opportunities for you. Any buyer or seller can look through online ads to find a few retail solutions. At SOLJETS, our team goes where others won't to find the right buyer or seller. We've built deep ties with manufacturers, lenders, insurers, and global operators so that we are in a position to not only hear about transaction opportunities before others, but to be instrumental in making those opportunities work for you.